

TREE PROTECTION NOTES:

- GENERAL MECHANICAL DAMAGE - SEE ABOVE FOR CORRECT ROOT ZONE CALCULATION AND PLACEMENT OF TREE PROTECTION.
- BOX TREES WITHIN 25 FEET (25') OF A BUILDING SITE TO PREVENT MECHANICAL INJURY, FENCING OR OTHER BARRIER SHOULD BE INSTALLED BEYOND THE CRITICAL ROOT RADIUS (CRR). TREE ROOT SYSTEMS COMMONLY EXTEND WELL BEYOND THE DRIP LINE.
- BOARDS WILL NOT BE NAILED TO TREES DURING BUILDING OPERATIONS.
- FEEDEE ROOTS SHOULD NOT BE CUT IN AN AREA INSIDE THE PROTECTED ROOT ZONE (PRZ).
- DAMAGED TRUNKS OR EXPOSED ROOTS SHOULD HAVE DAMAGED BARK REMOVED IMMEDIATELY AND NO PAINT SHALL BE APPLIED. EXPOSED ROOTS SHALL BE PRUNED TO GIVE A CLEAN, SHARP SURFACE AMENABLE TO HEALING. ROOTS EXPOSED DURING HOT WEATHER SHOULD BE IRRIGATED TO PREVENT PERMANENT TREE INJURY. CARE FOR SERIOUS INJURY SHOULD BE PRESCRIBED BY A PROFESSIONAL FORESTER OR LICENSED TREE EXPERT.
- TREE LIMB REMOVAL, WHERE NECESSARY, WILL BE DONE AS NATURAL TARGET PRUNING TO REMOVE THE DESIRED BRANCH AS CLOSE AS POSSIBLE TO THE BRANCH COLLAR. THERE SHOULD BE NO FLUSH CUTS. FLUSH CUTS DESTROY A MAJOR DEFENSE SYSTEM OF THE TREE. NO TREE PAINT SHALL BE APPLIED. ALL CUTS SHALL BE MADE AT THE OUTSIDE EDGE OF THE BRANCH COLLAR. CUTS MADE TO FAR BEYOND THE BRANCH COLLAR MAY LEAD TO EXCESS SPROUTING, CRACKS, AND ROT. REMOVAL OF A "Y" CROTCH SHOULD BE CONSIDERED FOR FREE STANDING SPECIMEN TREES TO AVOID FUTURE SPLITTING DAMAGE.
- FOR MORE SPECIFIC DATA ON CERTAIN TREE CHARACTERISTICS BY SPECIES, SEE TABLE 5.1. TREE CHARACTERISTICS OF THE STANDARDS FOR SOIL EROSION AND SEDIMENT CONTROL IN NEW JERSEY, JANUARY 2014, OR CONSULT WITH A LICENSED PROFESSIONAL TREE EXPERT, SOIL CONSERVATION DISTRICT OR Rutgers COOPERATIVE EXTENSION.

TREE PROTECTION DETAIL
SCALE: N.T.S.

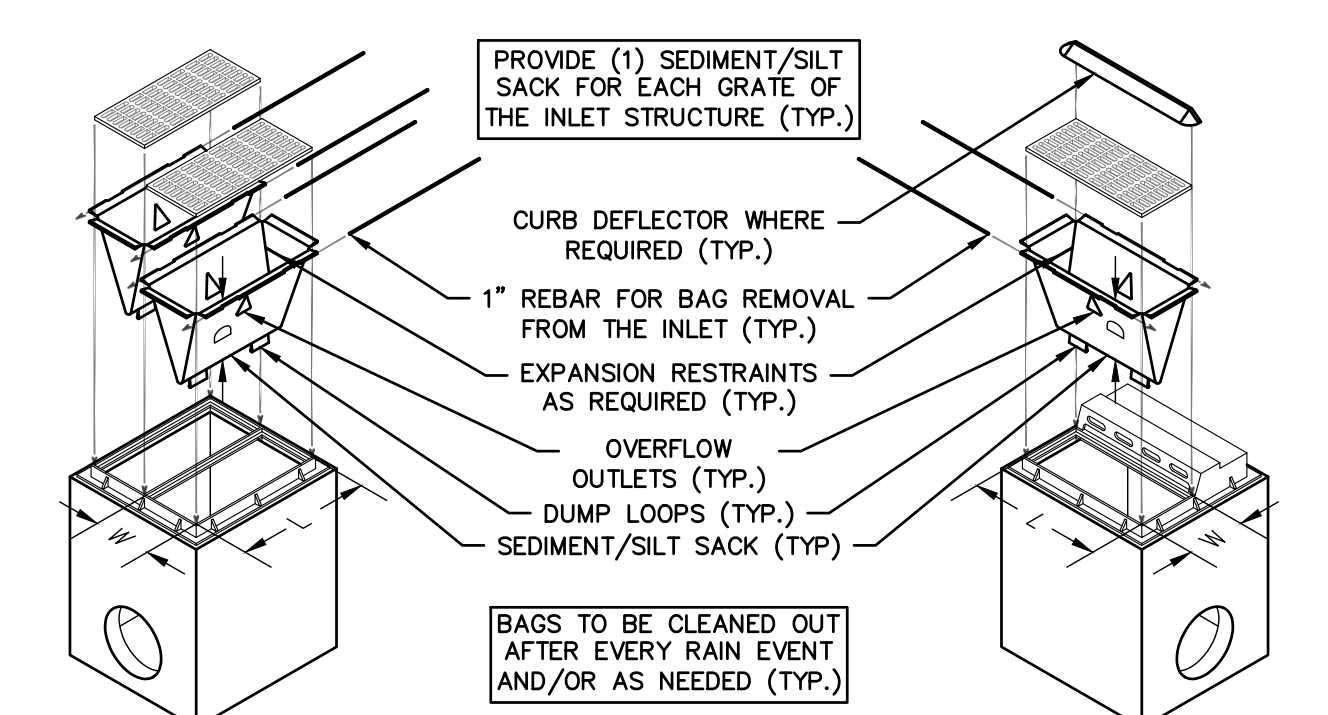

NOTES:

- INLET PROTECTION SHALL NOT BE REQUIRED FOR INLET TRIBUTARY TO AN ACTIVE SEDIMENT BASIN OR TRAP.
- 1' LENGTH W x WIDTH D x DEPTH DEPTH NOT EXCEED DEPTH OF BASIN TO TOP OF HIGHEST PIPE.
- INLET FILTER BAGS SHALL BE INSPECTED ON A WEEKLY BASIS AND AFTER EACH RAIN EVENT. BAGS SHALL BE EMPTIED AND RINSED OR REPLACED WHEN FULL OR WHEN FLOW CAPACITY HAS BEEN REDUCED SO AS TO CAUSE FLOODING OR BY PASSING OF THE INLET. DAMAGED BAGS SHALL BE REPLACED. A SUPPLY SHALL BE MAINTAINED ON SITE FOR REPLACEMENT OF BAGS. ALL NEEDED REPAIRS SHALL BE INITIATED IMMEDIATELY AFTER THE INSPECTION.
- OVERFLOW OUTLETS TO BE SIZED TO SAFELY PASS STORMS GREATER THAN THE 1 YEAR, 24 HOUR STORM EVENT.
- EXPANSION RESTRAINTS TO CONSISTING OF 1/2" NYLON ROPE WITH 2" FLAT WASHERS, TO BE INSTALLED AS RECOMMENDED BY THE MANUFACTURER.

STORM SEWER INLET PROTECTION DETAIL
SCALE: N.T.S.

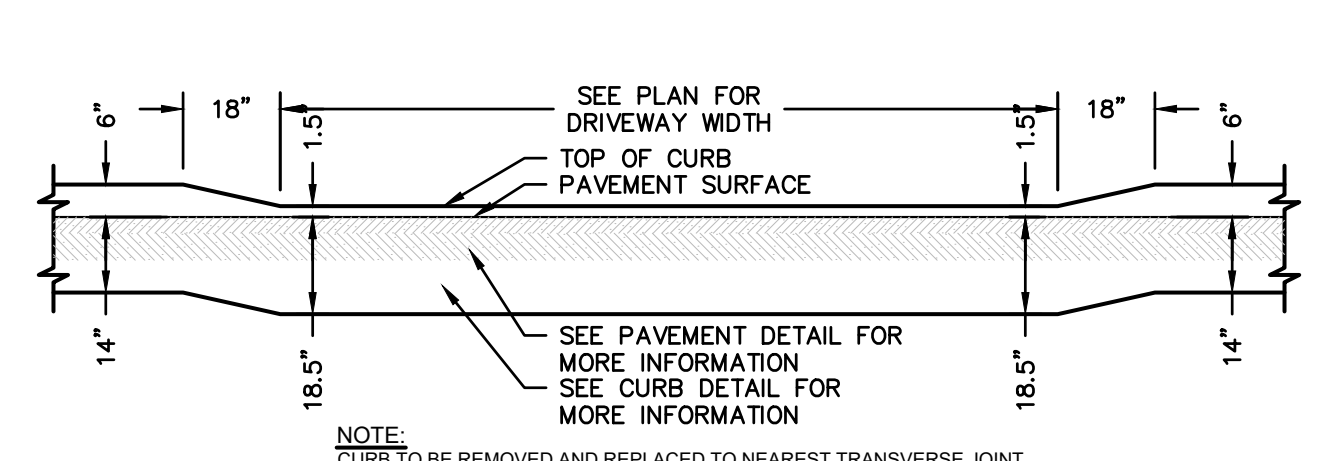

DEPRESSED CURB DETAIL
SCALE: N.T.S.

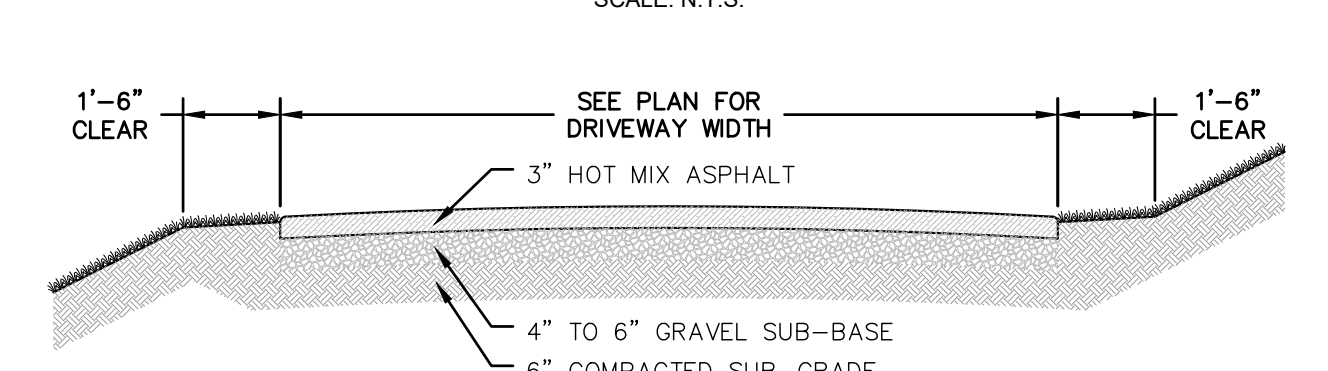

PAVED DRIVEWAY DETAIL
SCALE: N.T.S.

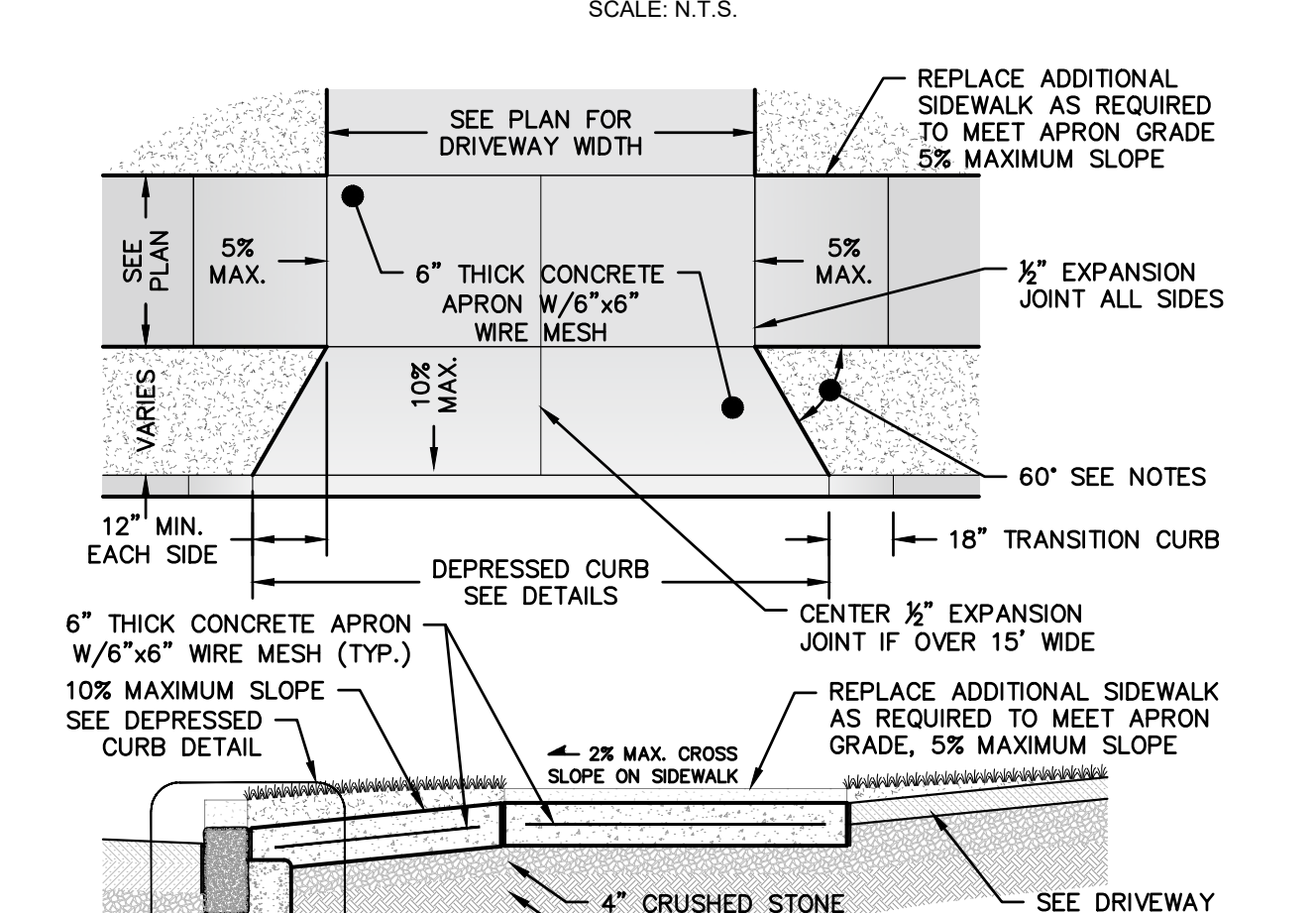

CONCRETE APRON DETAIL
SCALE: N.T.S.

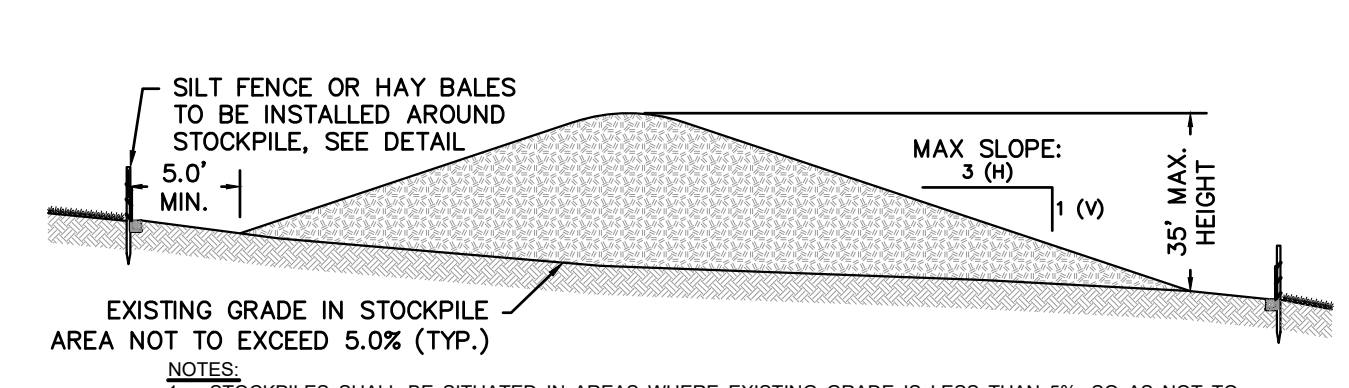

NOTES:

- STOCKPILES SHALL BE SITUATED IN AREAS WHERE EXISTING GRADE IS LESS THAN 5%, SO AS NOT TO OBSTRUCT NATURAL DRAINAGE OR CAUSE OFF-SITE ENVIRONMENTAL DAMAGE. SOIL STOCKPILES IN LOCATIONS OTHER THAN THOSE SHOWN ON THE PLANS SHALL BE APPROVED BY THE ENGINEER.
- ONCE SHAPED, STOCKPILES SHALL BE STABILIZED IN ACCORDANCE WITH THE STANDARDS FOR PERMANENT OR TEMPORARY VEGETATIVE COVER FOR SOIL STABILIZATION, AS APPROPRIATE (SEE NOTES).

SOIL STOCKPILE DETAIL
SCALE: N.T.S.

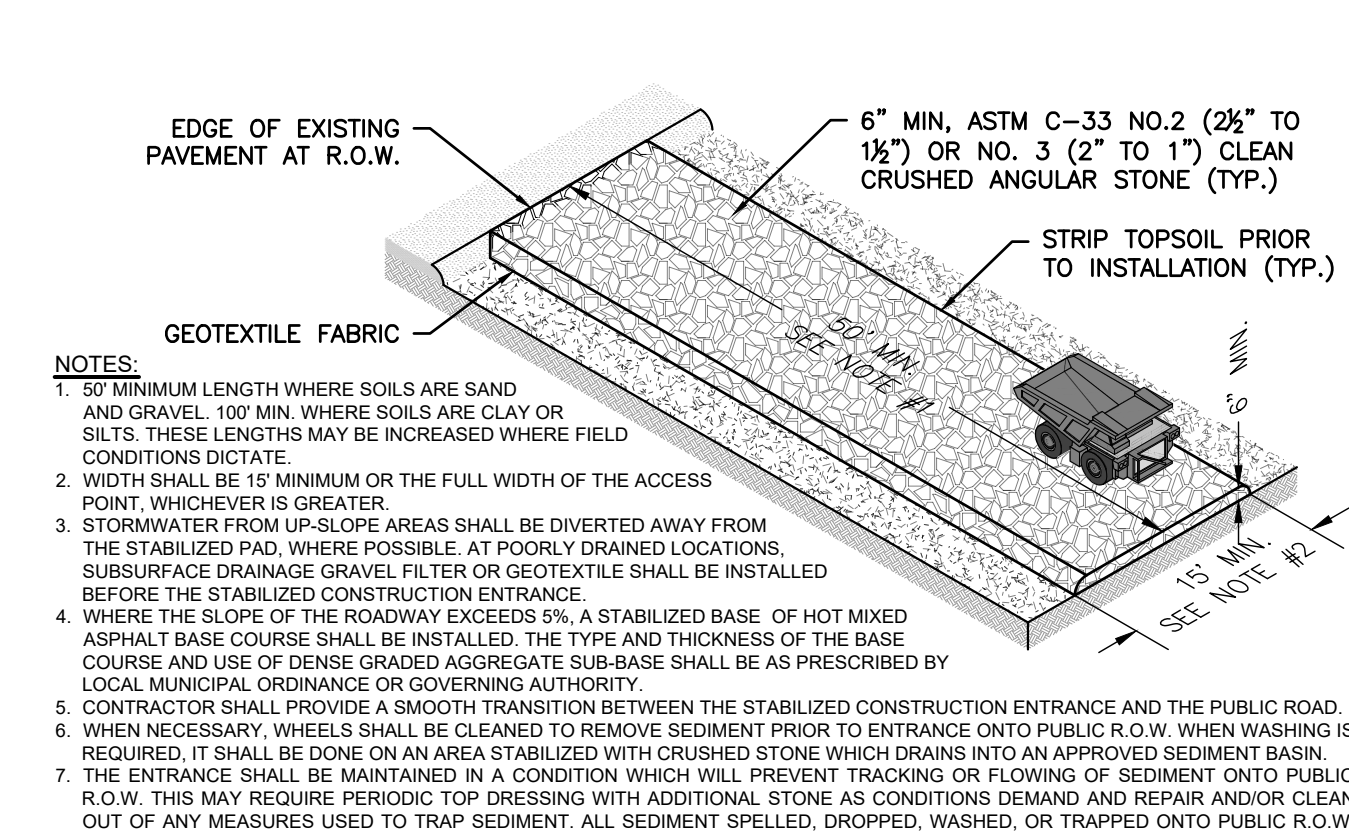

NOTES:

- MINIMUM LENGTH WHERE SOILS ARE SAND AND GRAVEL 100' MIN. WHERE SOILS ARE CLAY OR SILTS, THESE LENGTHS MAY BE INCREASED WHERE FIELD CONDITIONS DICTATE.
- WIDTH SHALL BE 15' MINIMUM OR THE FULL WIDTH OF THE ACCESS POINT, WHICHEVER IS GREATER.
- STORMWATER FROM UP-SLOPE AREAS SHALL BE DIVERTED AWAY FROM THE STABILIZED PAD, WHERE POSSIBLE. AT POORLY DRAINED LOCATIONS, SUBSURFACE DRAINAGE GRAVEL FILTER OR GEOTEXTILE SHALL BE INSTALLED BEFORE THE STABILIZED CONSTRUCTION ENTRANCE.
- WHERE THE SLOPE OF THE ROADWAY EXCEEDS 5%, A STABILIZED BASE OF HOT MIX ASPHALT BASE COURSE SHALL BE INSTALLED. THE TYPE AND THICKNESS OF THE BASE COURSE AND USE OF DENSE GRADED AGGREGATE SUB-BASE SHALL BE AS PRESCRIBED BY LOCAL MUNICIPAL ORDINANCE OR GOVERNING AUTHORITY.
- CONTRACTOR SHALL PROVIDE A SMOOTH TRANSITION BETWEEN THE STABILIZED CONSTRUCTION ENTRANCE AND THE PUBLIC ROAD.
- WHEN NECESSARY, WHEELS SHALL BE CLEANED TO REMOVE SEDIMENT PRIOR TO ENTRANCE ONTO PUBLIC R.O.W. WHEN WASHING IS REQUIRED, IT SHALL BE DONE ON AN AREA STABILIZED WITH CRUSHED STONE WHICH DRAINS INTO AN APPROVED SEDIMENT BASIN.
- THE ENTRANCE SHALL BE MAINTAINED IN A CONDITION WHICH WILL PREVENT TRACKING OR FLOWING OF SEDIMENT ONTO PUBLIC R.O.W. THIS MAY REQUIRE PERIODIC TOP DRESSING WITH ADDITIONAL STONE AS CONDITIONS DEMAND AND REPAIR AND/OR CLEAN OUT OF ANY MEASURES USED TO TRAP SEDIMENT. ALL SEDIMENT SPOILED, DROPPED, WASHED, OR TRAPPED ONTO PUBLIC R.O.W. MUST BE REMOVED IMMEDIATELY.

STABILIZED CONSTRUCTION ENTRANCE
SCALE: N.T.S.

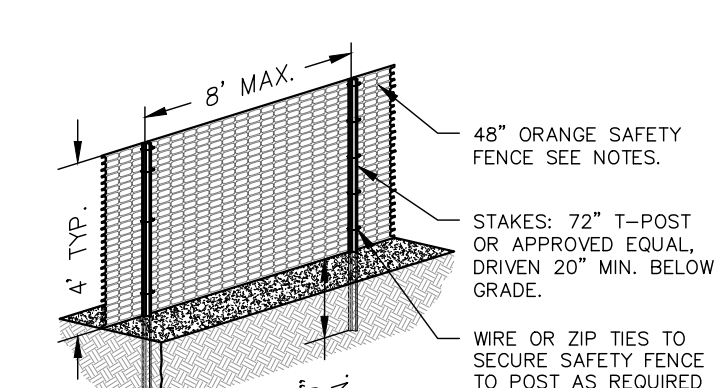

NOTES:

- CONSTRUCTION FENCE TO BE INSTALLED ON ALL LIMITS OF DISTURBANCE AND AROUND ANY SENSITIVE AREAS TO BE PROTECTED DURING CONSTRUCTION.
- CONSTRUCTION FENCING TO BE ORANGE, POLYETHYLENE OR POLYPROPYLENE AND SHALL BE HIGHLY VISIBLE. THE FENCE MATERIAL SHALL HAVE AN ULTRAVIOLET COATING.
- FENCING MUST REMAIN IN PLACE AND MAINTAINED DURING ALL PHASES OF CONSTRUCTION; AND CHANGES TO THE PROTECTIVE FENCING MUST BE APPROVED.

CONSTRUCTION FENCE
SCALE: N.T.S.

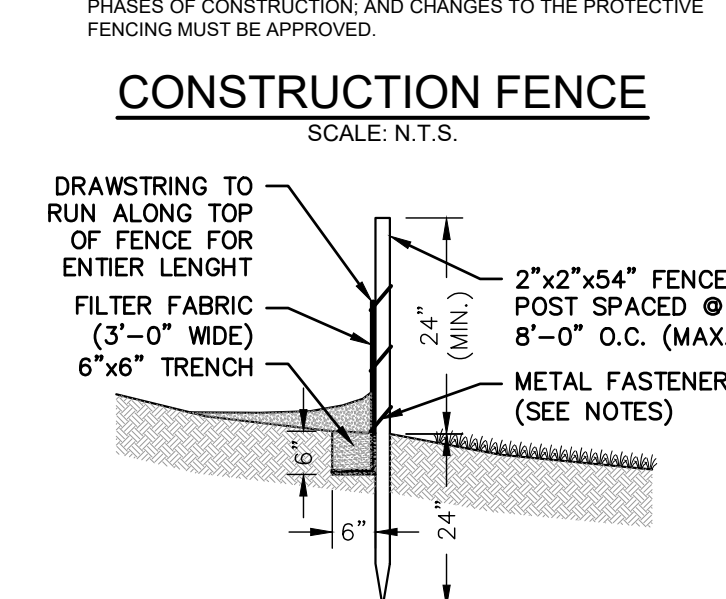

NOTES:

1. FILTER FABRIC TO BE MIRAFI 100X OR APPROVED EQUAL.
2. BURY BOTTOM 12" OF FILTER FABRIC IN 6"x6" TRENCH AND STAMP IN PLACE.
3. SECURE FILTER FABRIC TO POSTS WITH METAL FASTENERS AND REINFORCEMENT BETWEEN FABRIC AND FASTENER.
4. ENDS OF REVERSAL ROLLS OF FILTER FABRIC TO BE WRAPPED AROUND A COMMON POST TWICE AND SECURELY FASTENED.
5. FOR HEAVY DUTY SILT FENCE, INSTALL WIRE MESH (14 GA W/ 4" OPENINGS) BEHIND FILTER FABRIC. SECURE WITH WIRE TIES OR STAPLES.

SILT FENCE DETAIL
SCALE: N.T.S.

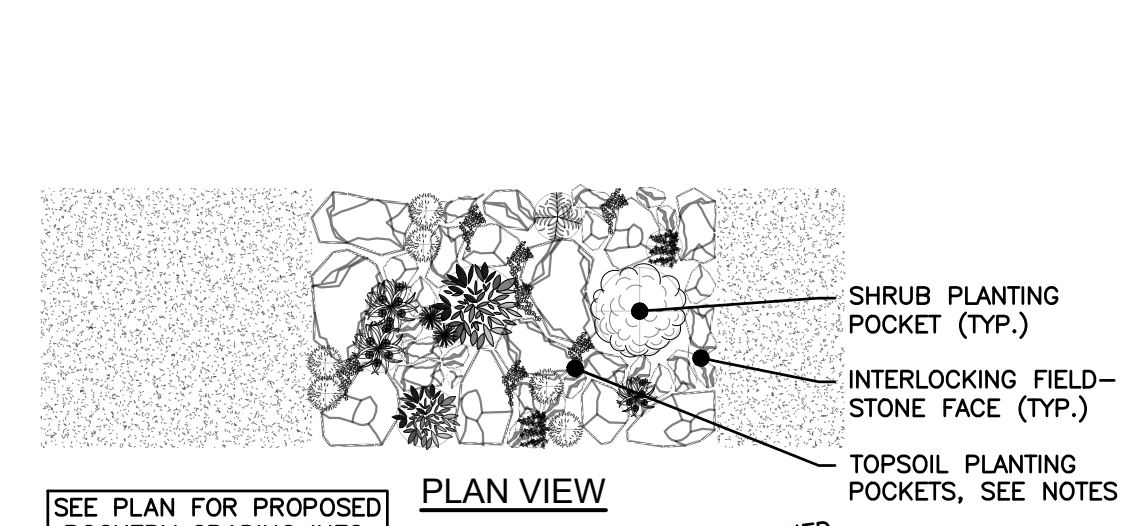

NOTES:

- 4:0" MAXIMUM ROCKERY HEIGHT ABOVE EMBEDMENT. SEE PLAN FOR ACTUAL HEIGHT.
- ALL EXISTING TOPSOIL AND ORGANIC MATERIAL, TO BE STRIPPED PRIOR TO CONSTRUCTION. SUB-GRADE TO BE FREE FROM OVERSIZED COBBLES, RUBBISH, TOP SOIL, SOD, GRASS, ROOTS OR OTHER UNSTABLE MATERIALS.
- FOUNDATION TO BE LEVEL FROM FRONT TO BACK.
- FIELDSTONES TO BE A MINIMUM OF 18" DIAMETER, AND SHALL BE CHISELED TO FIT AND/OR MATCHED TO BE INTERLOCKING AND CHINKED AS NECESSARY. GAPS BETWEEN STONES, TO ALLOW DRAINAGE OF PLANTING POCKETS, TO BE FILLED WITH FILTER MATERIAL AS REQUIRED.
- FILTER MATERIAL TO BE NOT STANDARD NUMBER 4 WASHED GRAVEL OR CRUSHED STONE, FREE OF FINES SUCH AS DUST, ASH OR CLAY, IN ACCORDANCE TO MIDDOT 601.03.02.
- SMALL TOPSOIL PLANTING POCKETS TO BE SCATTERED ACROSS ROCKERY FACE, FOR GRASSES, FLOWERS, AND GROUND COVER. POCKETS TO BE 6" MINIMUM DEPTH, AND BE SURROUNDED AND SUPPORTED BY FIELDSTONES. LARGER POCKETS FOR SHRUBS SHALL BE A MINIMUM OF 24" POT OR ROOT BALL DIAMETER. DEPTH SHALL BE IN ACCORDANCE TO THE PLANTING SPECIFICATIONS AND DETAILS.
- GEOTEXTILE FILTER FABRIC TO BE INSTALLED ON ALL SIDES OF FILTER MATERIAL TO PREVENT THE MIGRATION OF FINE PARTICLES FROM THE SURROUNDING SOIL. FILTER FABRIC TO MEET US ARMY CORPS OF ENGINEERS GUIDE SPECIFICATIONS, CWD215-86 FOR STRENGTH.

FIELD STONE ROCKERY DETAIL
SCALE: N.T.S.

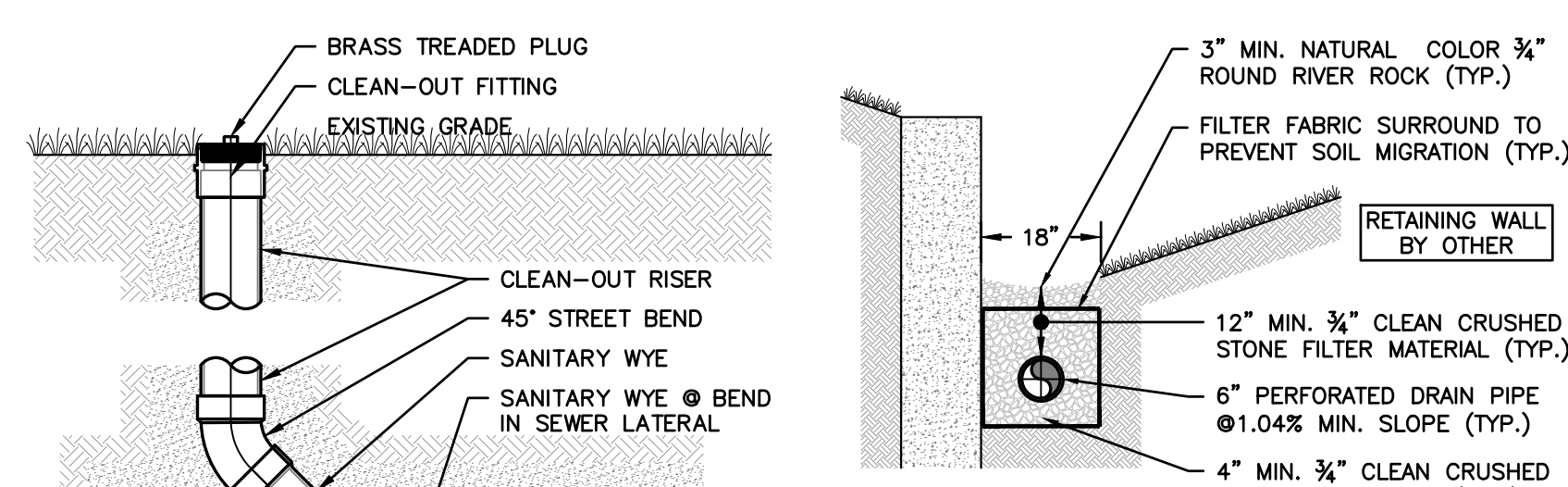

NOTES:

- CLEAN-OUTS TO BE INSTALLED AT ALL LOCATIONS MARKED IN THE PLANS AND EVERY 75 FEET ALONG SEWER LATERAL, UNLESS OTHERWISE SPECIFIED. DO NOT INSTALL CLEAN-OUTS IN INACCESSIBLE AREAS.
- ALL CLEAN-OUT PIPING TO BE THE SAME SIZE AND MATERIAL AS SEWER LATERAL, UNLESS OTHERWISE SPECIFIED. SEE PLAN FOR PIPE INFORMATION.
- ALL NON-STREET SOCKET WELDED FITTINGS TO BE SPACED AT TWICE STANDARD SOCKET DEPTH.
- SANITARY WYE @ 45° STREET BEND CAN BE REPLACED WITH LONG SWEEP SANITARY WYE, WHERE APPLICABLE.
- FOR CLEAN-OUTS IN AREAS OF VEHICULAR TRAFFIC, SEE CLEAN-OUT PROTECTION BOX DETAIL.

STORMWATER CLEAN-OUT DETAIL
SCALE: N.T.S.

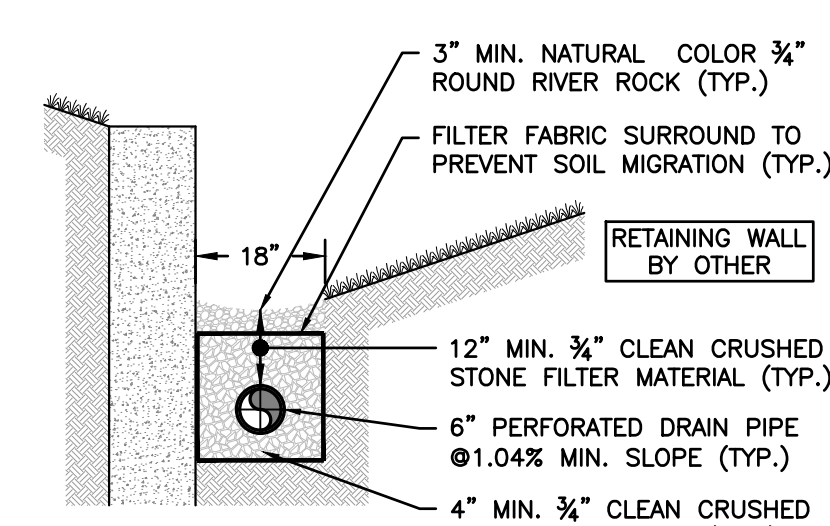

NOTES:

- OPTIONAL POLY EDGING TO BE INSTALLED ALONG PERIMETER OF RIVER ROCK TO PREVENT STONE MIGRATION. EDGING TO BE INSTALLED AS TO NOT IMPEDE FLOW INTO DRAINAGE TRENCH.
- FILTER FABRIC TO OVERLAP A MINIMUM OF 6".

GRAVEL DRAINAGE SWALE DETAIL
SCALE: N.T.S.

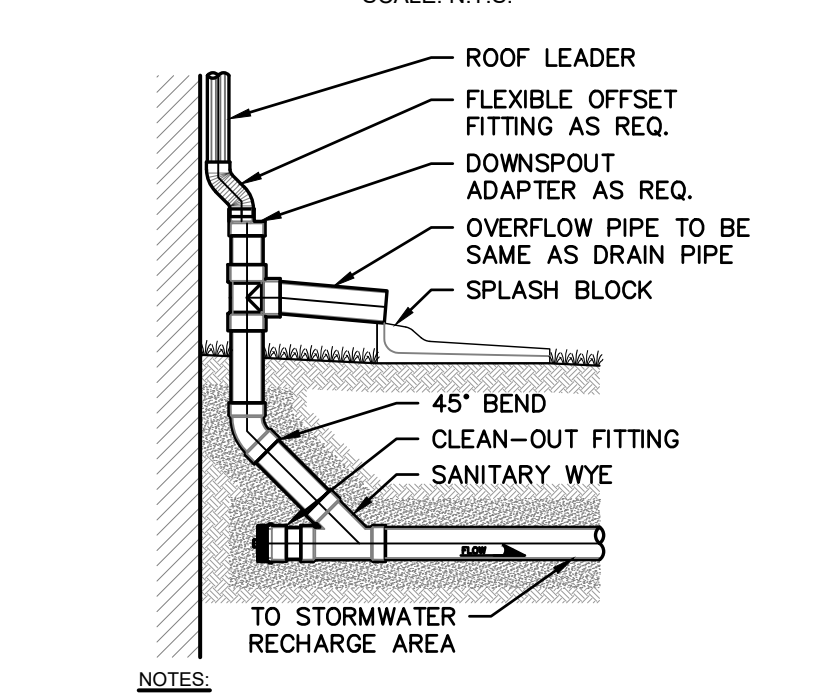

NOTES:

- ALL PIPING TO BE THE SAME SIZE AND MATERIAL AS SPECIFIED IN THE PLANS.
- CLEAN-OUT TO BE INSTALLED AT ALL LOCATIONS MARKED ON THE PLANS AND EVERY 50 FEET ALONG ROUTING TO RECHARGE AREA, UNLESS OTHERWISE SPECIFIED.

ROOF LEADER STORMWATER DISCHARGE DETAIL
SCALE: N.T.S.

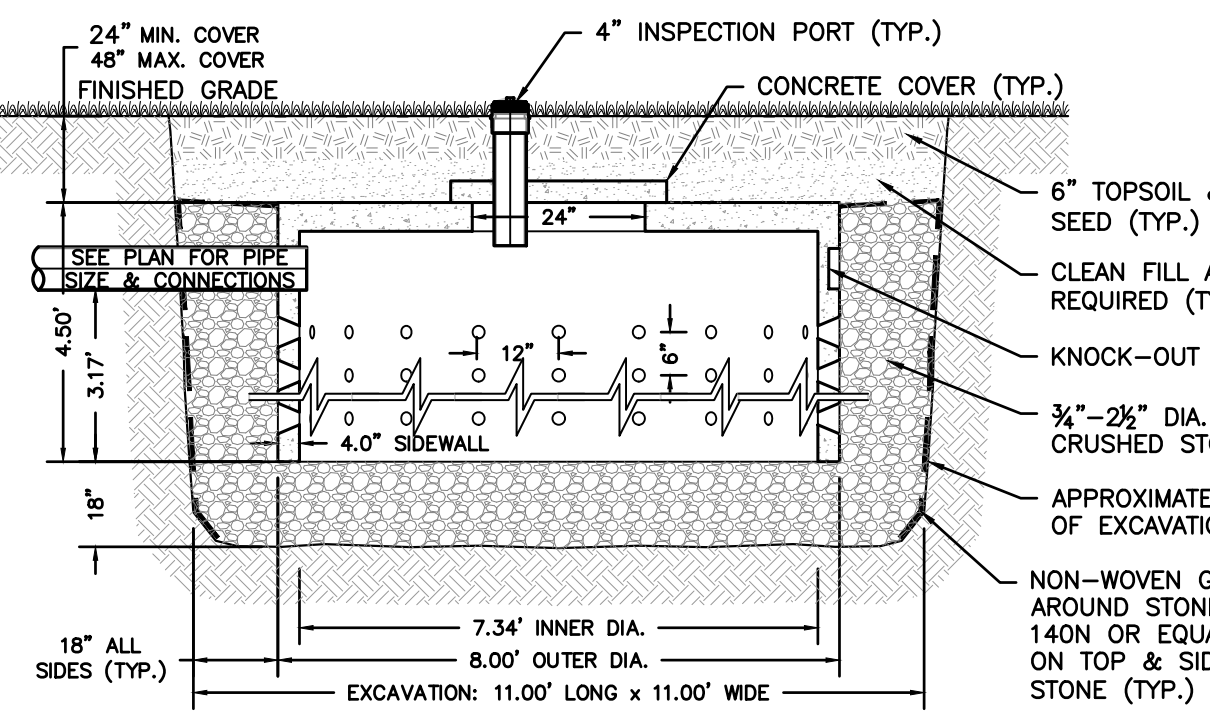

NOTES:

- ADEQUATE MEASURES SHALL BE USED TO INSURE THAT THE EXCAVATION BE CARRIED OUT IN A MANNER THAT WILL AVOID UNNECESSARY COMPACTION OF THE AREA, AND THAT THE BOTTOM OF THE EXCAVATION IS LEVEL.
- ALL JOINTS ABOVE THE INLET SHALL BE MADE WATER TIGHT.

STORMWATER 8.00' DIA. SEEPAGE PIT
SCALE: N.T.S.

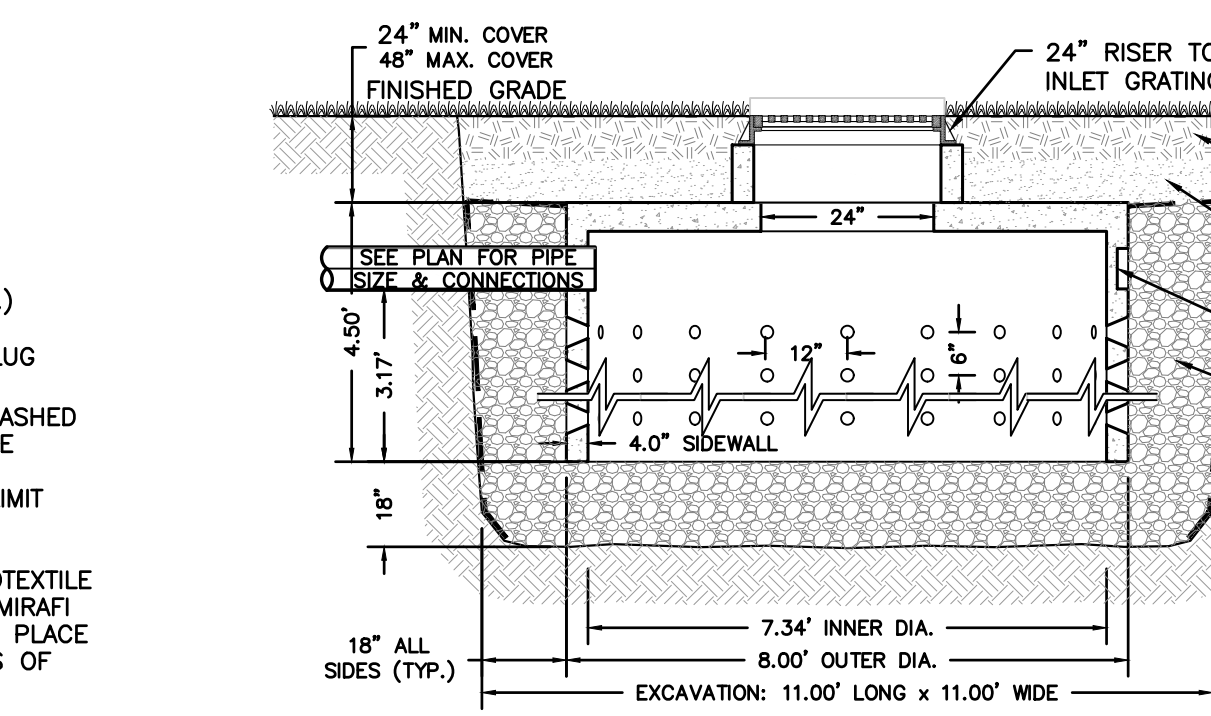

NOTES:

- ADEQUATE MEASURES SHALL BE USED TO INSURE THAT THE EXCAVATION BE CARRIED OUT IN A MANNER THAT WILL AVOID UNNECESSARY COMPACTION OF THE AREA, AND THAT THE BOTTOM OF THE EXCAVATION IS LEVEL.
- ALL JOINTS ABOVE THE INLET SHALL BE MADE WATER TIGHT.

STORMWATER 8.00' DIA. SEEPAGE PIT
SCALE: N.T.S.

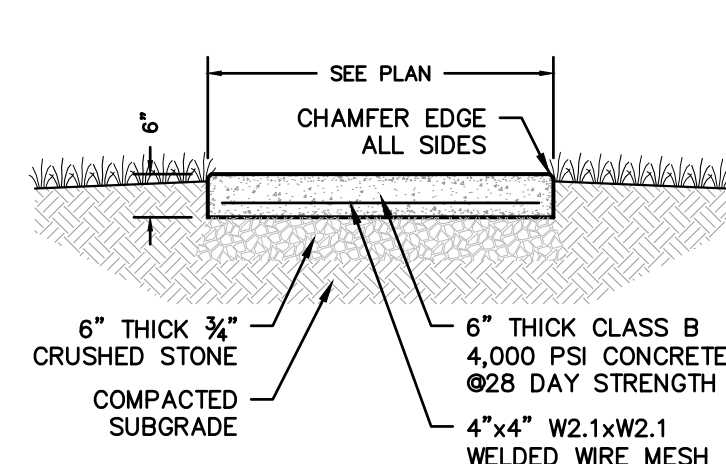

CONCRETE EQUIPMENT PAD
SCALE: N.T.S.

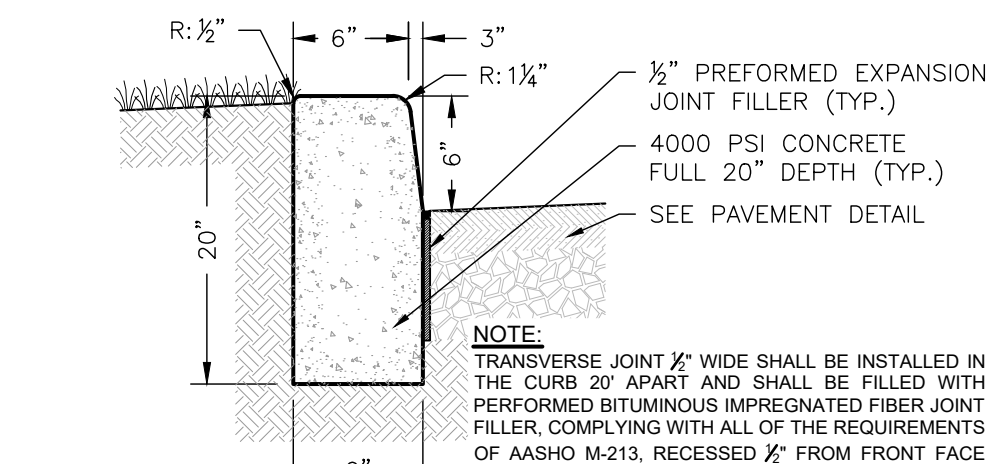

POURED CONCRETE CURB
SCALE: N.T.S.

NOTES:

- ALL PAVEMENT SHALL BE INSTALLED IN ACCORDANCE TO 5249-70 AS REQUIRED.
- MINIMUM CROSS SLOPE OF SIDEWALK TO BE 2% TOWARDS CURB.
- 1/2" EXPANSION JOINTS TO BE INSTALLED AT A MAXIMUM SPACING OF 15' ON CENTER.
- HAND TOOKED TRANSVERSE & LONGITUDINAL CONTRACTION JOINTS TO BE PROVIDED AT A MAXIMUM SPACING OF 5' ON CENTER.
- SIDEWALKS IN HIGH TRAFFIC AREAS TO BE REINFORCED WITH 6x6-W1.4W1.4 WELDED WIRE FABRIC.

VILLAGE OF RIDGEWOOD PAVEMENT SECTION & REPAIR STRIP DETAIL
SCALE: N.T.S.

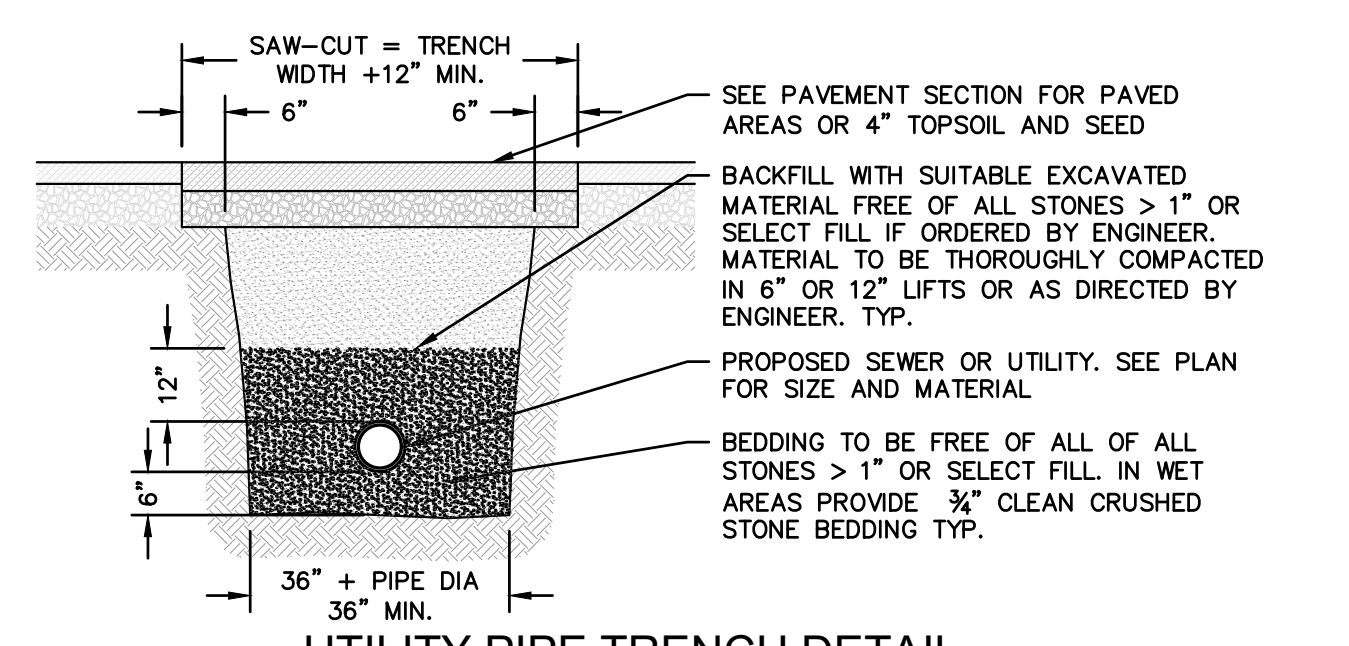

UTILITY PIPE TRENCH DETAIL
SCALE: N.T.S.

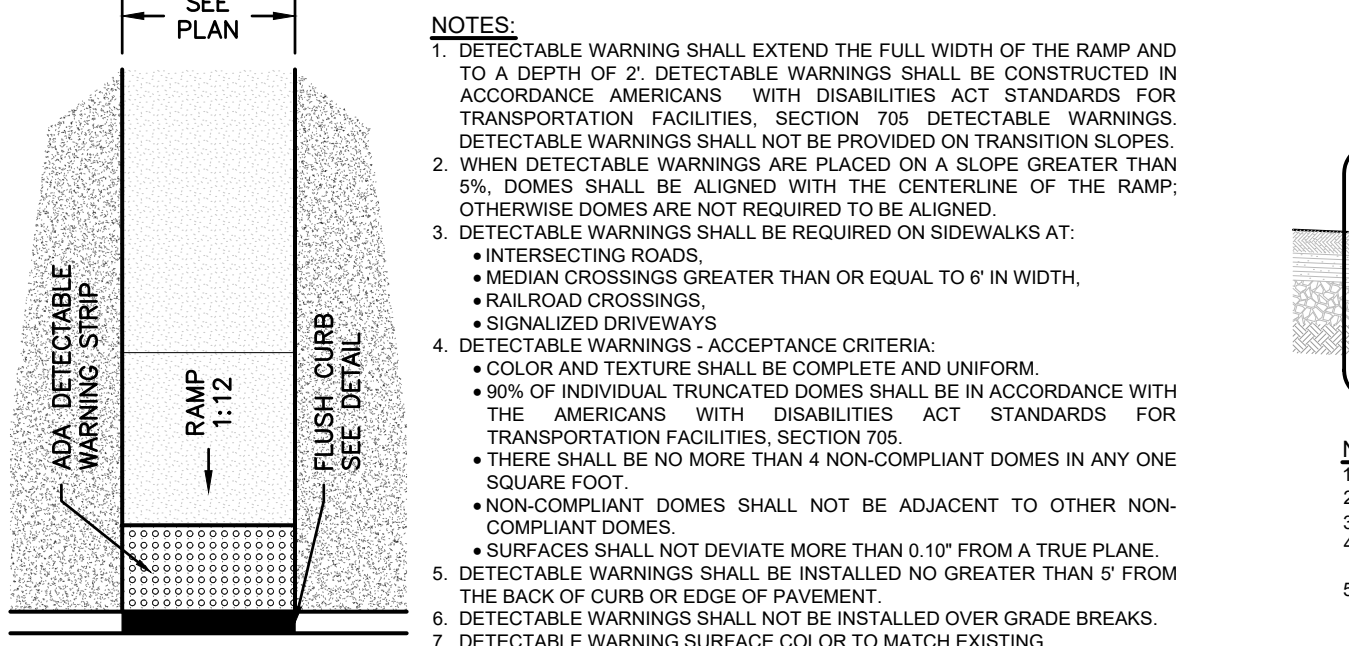

ADA DETECTABLE WARNINGS DETAIL
SCALE: N.T.S.

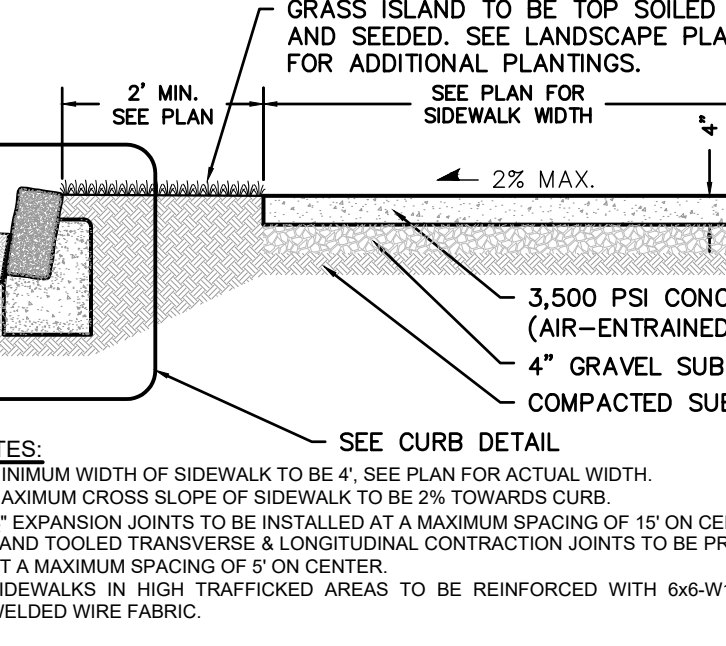

CONCRETE SIDEWALK W/ GRASS ISLAND
SCALE: N.T.S.

REV	COMMENT	DATE
9	REVISED PER BASE REFERENCES. ADDED AS-BUILT CONDITIONS TO COVERAGE & BULK TABLES	12/28/2023
8	ADDED BUILDING HEIGHT VARIANCE	11/17/2023
7	ADDED ELECTRIC CONDUIT TRACK PER REFERENCE	09/19/2023
6	REVISED PER BASE REFERENCE, REMOVED EXTERNAL SUMP	08/23/2023

PROJECT: **PROPOSED SINGLE FAMILY RESIDENCE**
488 OVERBROOK ROAD
VILLAGE OF RIDGEWOOD
BLOCK 3612, LOT 14

APPLICANT: **GUSFA**

BERGEN COUNTY NEW JERSEY

DRAWN BY: **BEB**
SCALE: **SEE SCALE**
DATE: **2/8/2023**
PROJECT NO.: **4278.22**
SHEET NO.: **2 OF 2**

J.R. HOUSER PROFESSIONAL ENGINEER
NEW JERSEY LICENSE NO. 24GE04747700
PENNSYLVANIA LICENSE NO. PE079324

HOUSER Engineering, LLC
1141 Greenwood Lake Tpke. Ringwood, NJ 07456
Tel: 973-728-2945 | Fax: 973-608-1524
www.housereng.com
NJ CERT. OF AUTH. NO.: 24GA28163600

T.C. VANDERVALK PROFESSIONAL ENGINEER
NEW JERSEY LICENSE NO. 24GE05165800