



INNOVATIVE CONSULTING ENGINEERS LLC
 44 SUNSET ROAD FAIRFIELD NJ 07004
 (908) 232 3950
 ICECOLLC@GMAIL.COM
 CERTIFICATE OF AUTHORIZATION
 #24GA28098900

GARY VEGLIANTE P.E. 33707 NJ

310 ABBEY CT.
 RIDGEWOOD, NJ

TITLE
 SECOND FLOOR FRAMING

REVISION

DATE 01.06.19
 SCALE 1/4"=1'
 DRAWN lmv
 REVISED GV

DRAWING

S-1
 ICE 19124

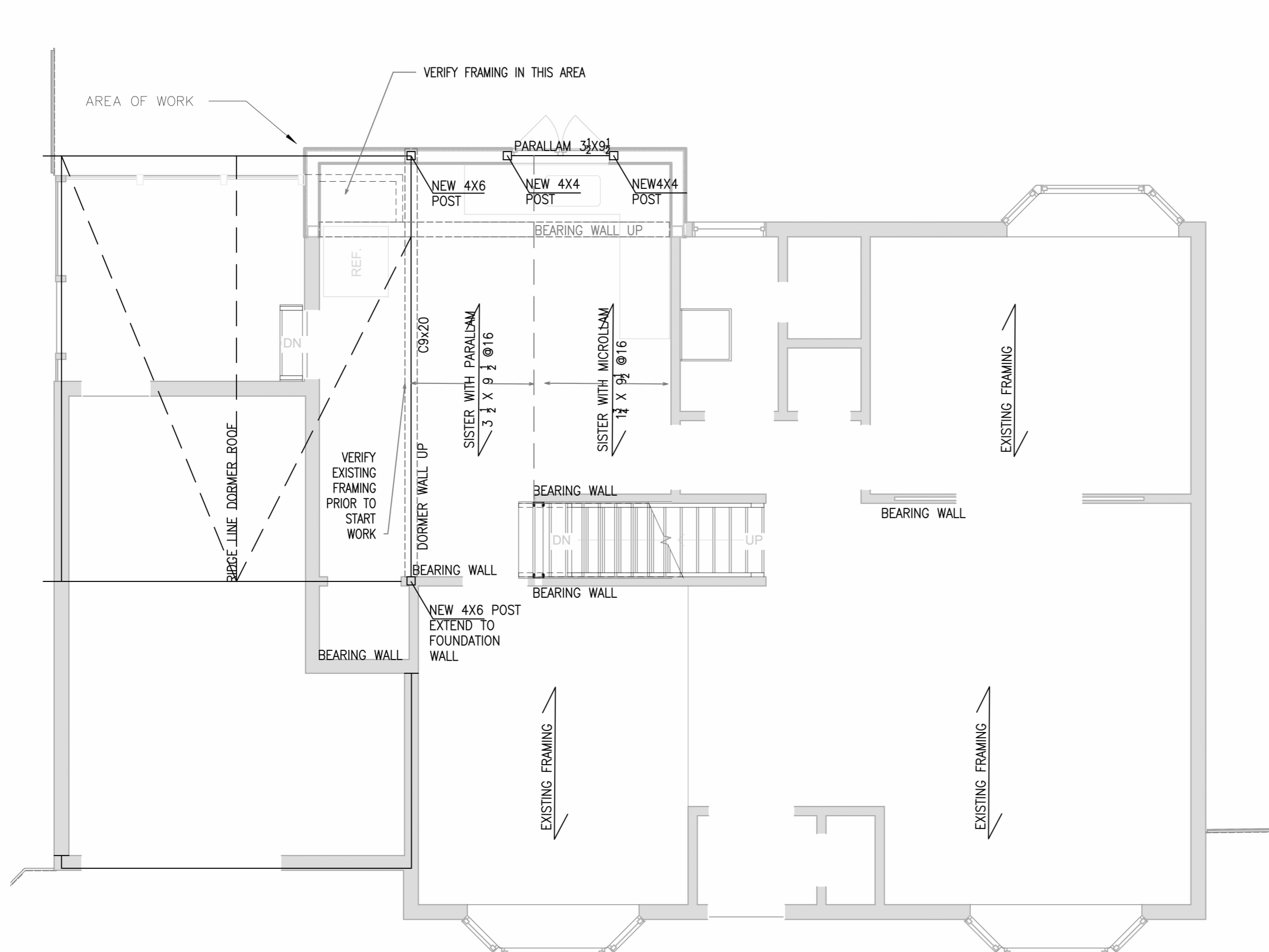

SECOND FLOOR FRAMING PLAN

SCALE 1/4"=1'

NOTE:

1. ALL POSTS ARE PARALLAM
2. BLOCK SOLID BETWEEN ALL JOISTS OVER GIRDERS AT EXISTING BEARING WALL

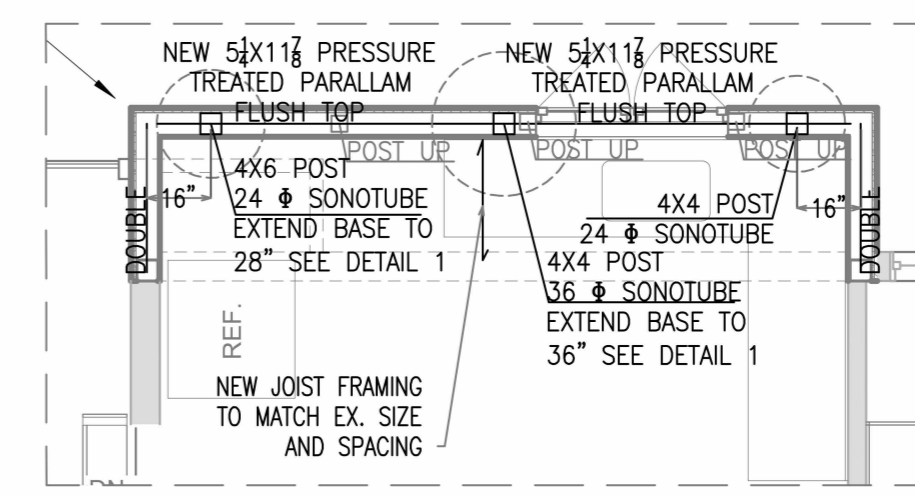

FIRST/FOUNDATION PART PLAN

SCALE 1/4"=1'

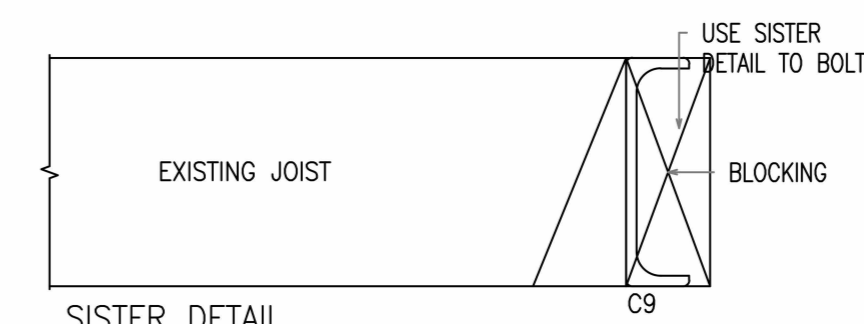

SISTER DETAIL

SCALE 1 1/2"=1'

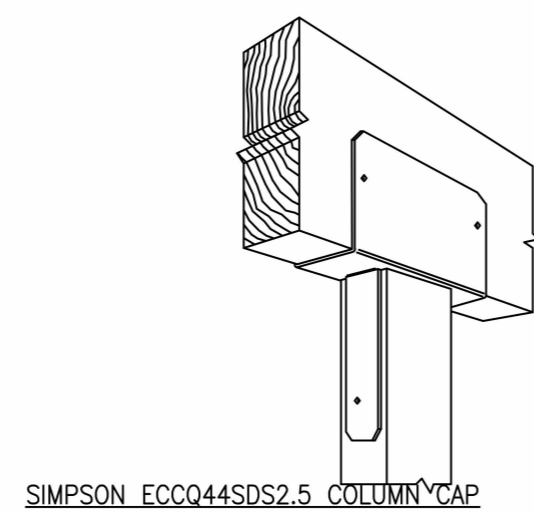
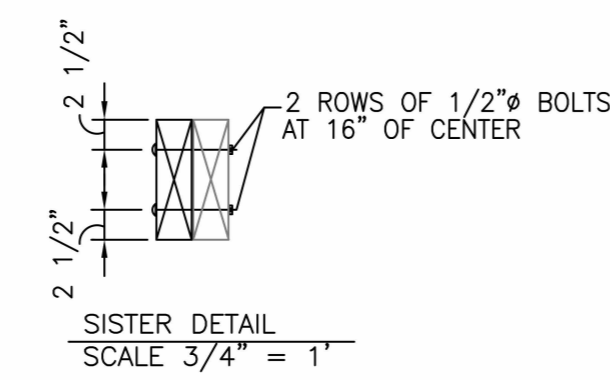
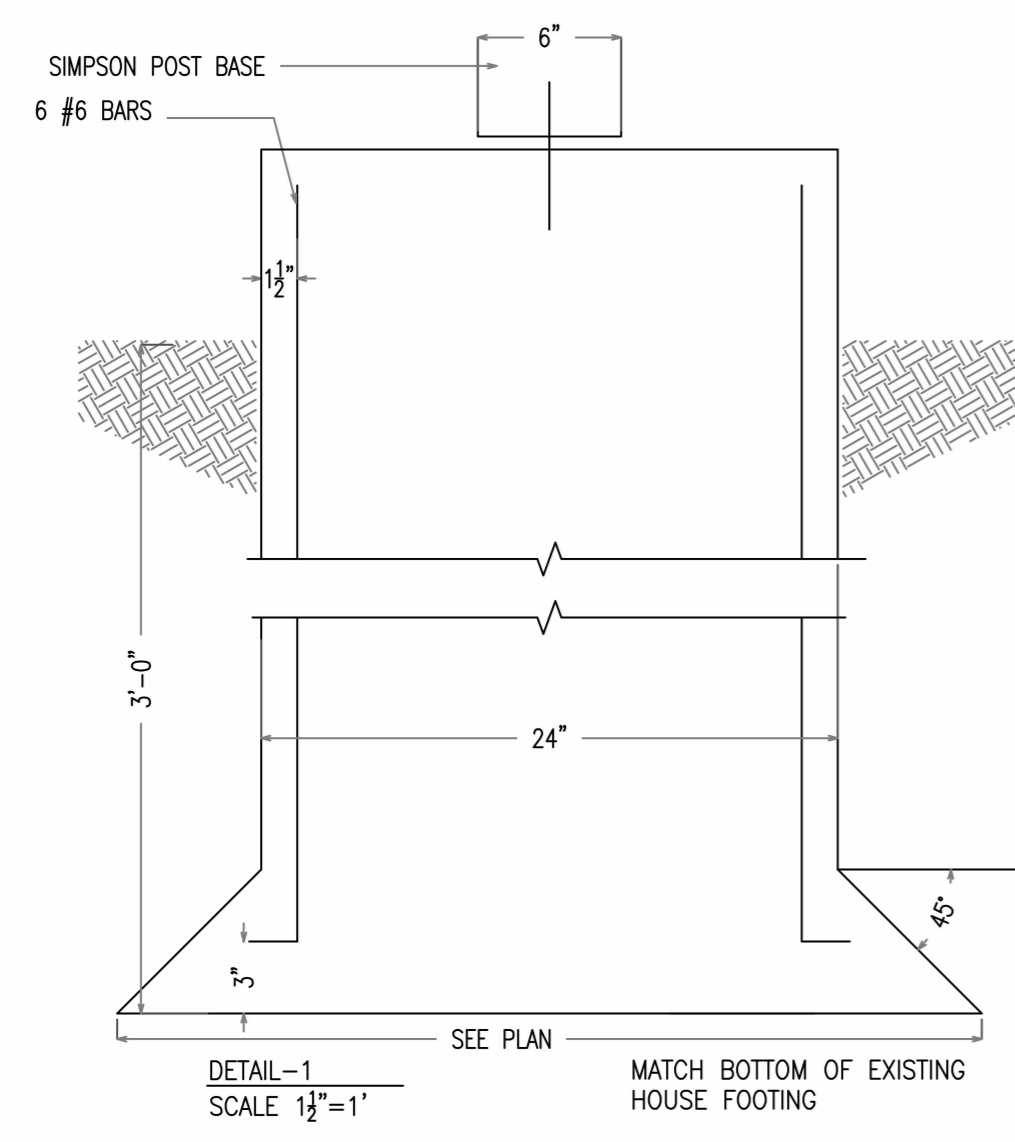

SIMPSON ECCQ44SDS2.5 COLUMN CAP

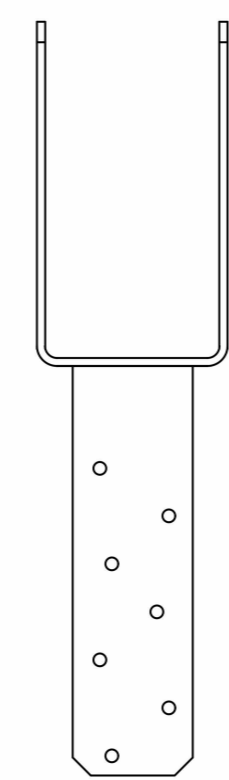

SIMPSON ECCQ44SDS2.5 COLUMN CAP

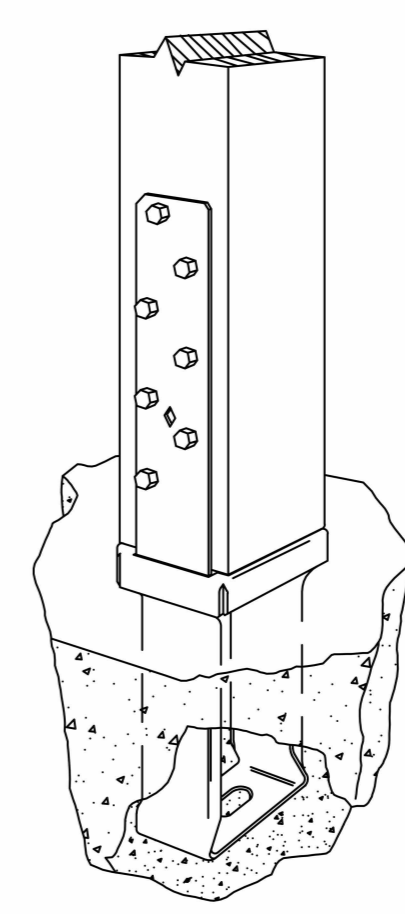
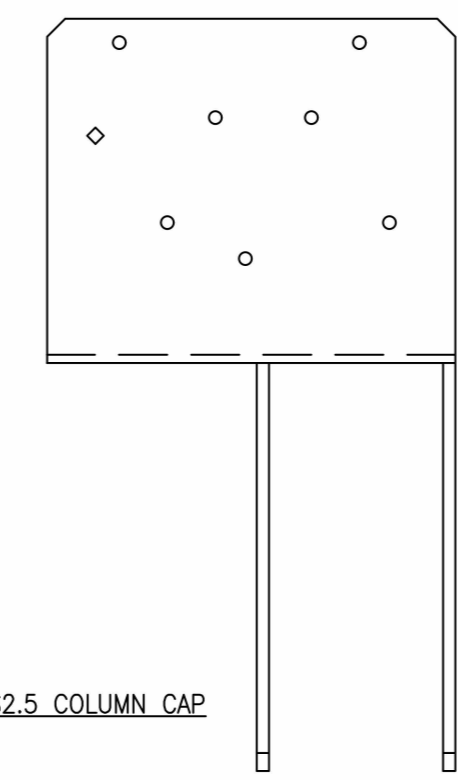

SIMPSON POST BASE CBSQ
 N.T.S.